

兴土股份装配式精铸卸落块 A 型

专用于桥梁支架标高调节与落架的工具

XINGTU A-SHAPE OF ASSEMBLED PRECISION CASTING UNLOADING BLOCK

Tools Specially Designed For Elevation Adjustment And Landing of Bridge Brackets

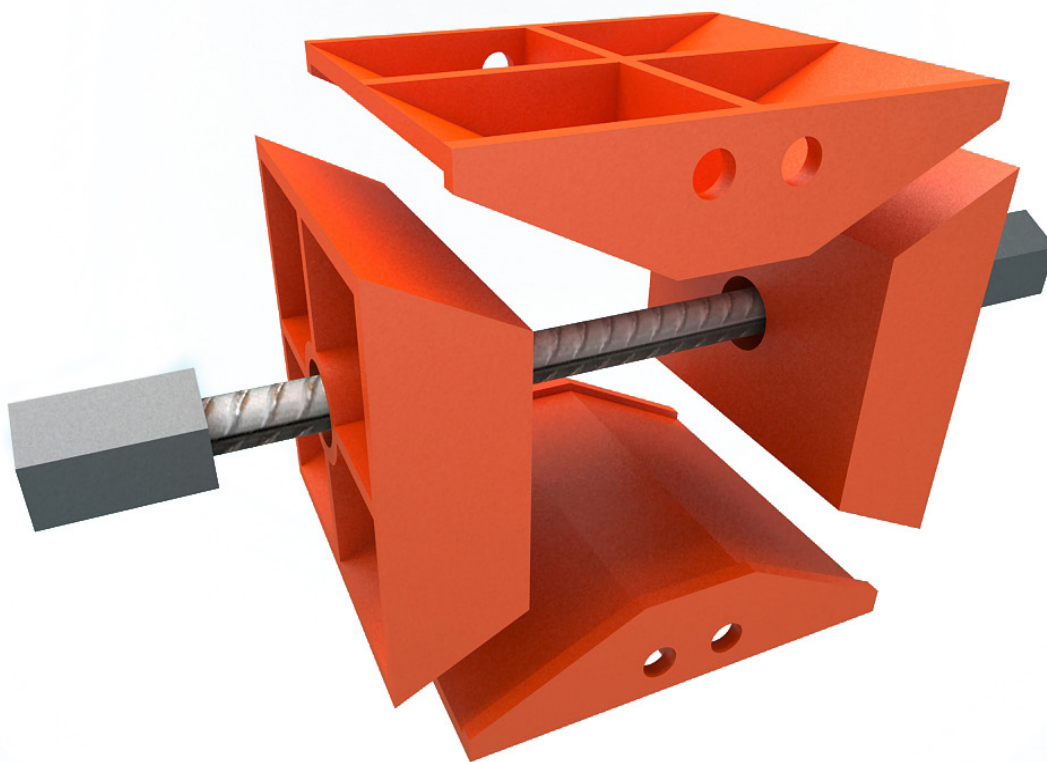

咨询热线
Advisory hotline

400-0000-661

www.zjxtql.com

经济 安全 高效 环保



XINGTU A-SHAPE OF ASSEMBLED PRECISION CASTING UNLOADING BLOCK DESIGN IDEA

兴土股份装配式精铸卸落块 A 型 设计理念

在桥梁施工中，支模架系统在现浇箱梁当中是必须使用的一种用于浇筑混凝土的承重结构。支模架在设计施工当中需要考虑施工标高的调节及控制方法，以及在浇筑完成混凝土主体结构后支架拆除的措施，这样就需要使用一种卸落装置去解决这些问题。

目前一般的做法为用卸落沙筒或者短型钢，但这些传统的卸落装置普遍为一次性消耗用材，材料投入成本大，制作、安装、拆除人工成本较高，且操作不便、安全性低。针对以上问题，为满足桥梁施工需求，兴土股份潜心研发出专用的装配式精铸卸落块。以铸钢作为原材料，采用精铸工艺，一次性浇铸成型，整体结构性强，可靠性高。

兴土股份装配式精铸卸落块，是专用于桥梁支架标高调节与落架的工具，可周转使用、标高调节方便、精度高、拆除成本较低，相对于传统的卸落装置充分体现了其专业、安全、经济、便捷的优势。

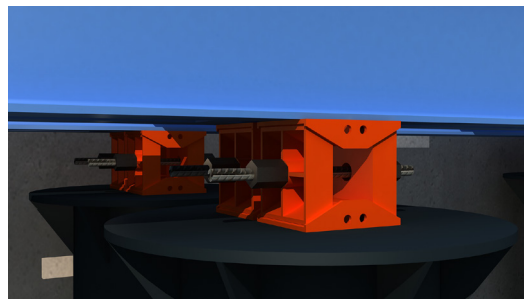
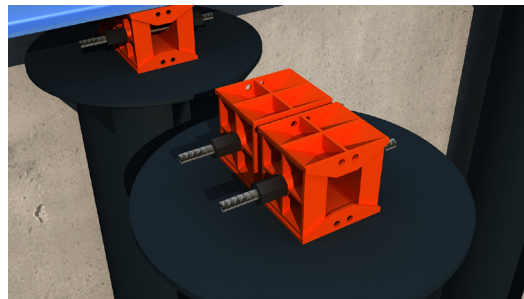
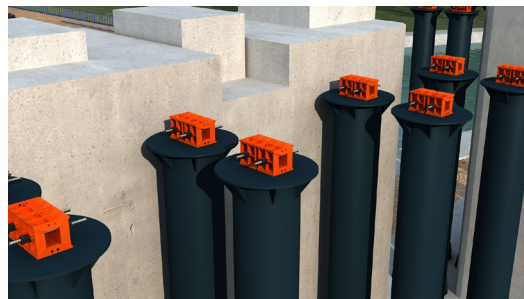

XINGTU A-SHAPE OF ASSEMBLED PRECISION CASTING
UNLOADING BLOCK APPLICABLE ENVIRONMENT

兴士股份装配式精铸卸落块 A 型 适用环境

落地钢支架

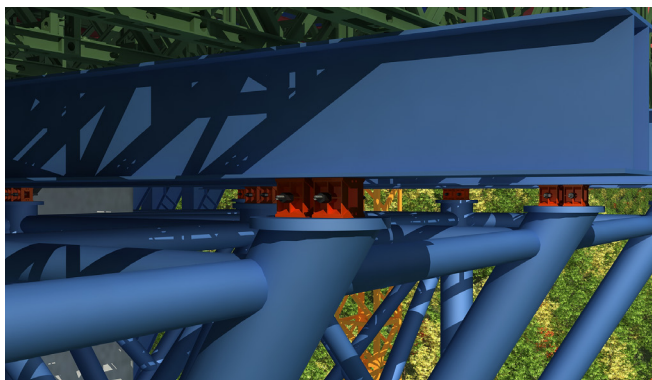
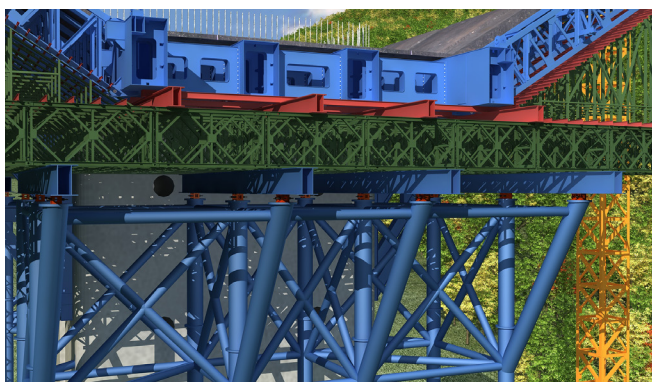

侧模板落架



三角托架

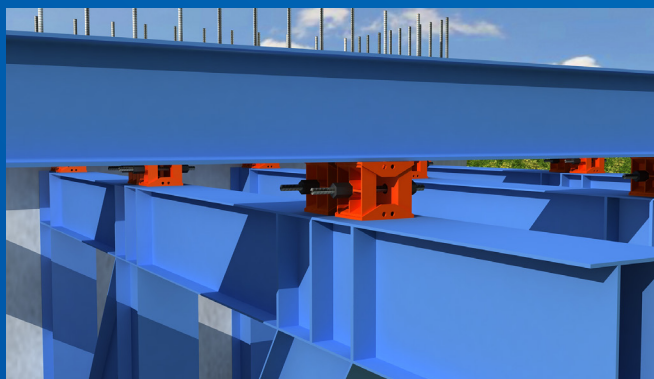

盖梁

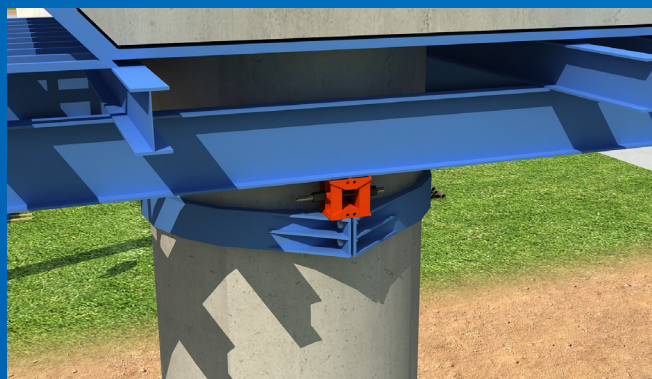

安全

SAFETY



高效

HIGH EFFICIENCY



经济

ECONOMY



美观

AESTHETIC



CONFIGURATION PARAMETERS OF XINGTU A-SHAPE OF ASSEMBLED PRECISION CASTING UNLOADING BLOCK

兴土股份装配式精铸卸落块 A 型配置参数

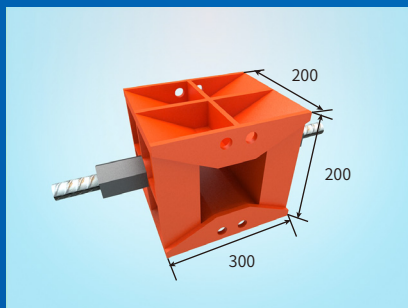

最低可调节标高 200mm

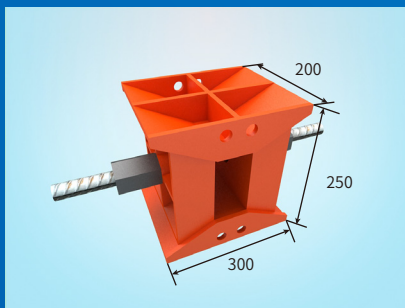

最高可调节标高 250mm

单个载重
100t

上下调节
5cm

单个自重
36.11kg



上支座



下支座

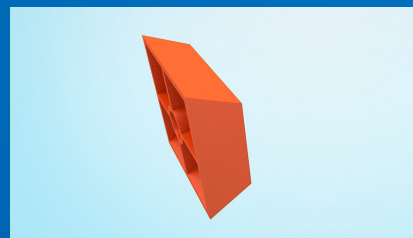

左支座



右支座



φ32 精轧螺纹钢筋

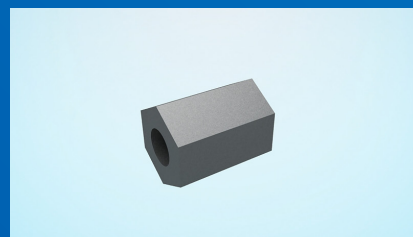

φ32 精轧螺纹钢螺母 (2个)

中国桥梁施工系统服务商
CHINA BRIDGE CONSTRUCTION SYSTEM SERVICE



地址(Add): 浙江省嘉兴市秀洲区新城街道成秀路251号
电话(Tel): 0573-83972615 邮箱(Email): zjxtql@126.com
传真(Fax): 0573-83972668 邮编(P.C.): 314000